

Main Feature



1. UDH Relay Series is designed with switching capacity by 12A to comply with user's selection.
2. Insulation distance 4 mm Min. is designed. The employment of insulation material is meeting to JIS Insulation Class E. The Dielectric Strength of 2,000VAC Min. and Surge Resistance of 5,000V can be reached.
3. 2.54 mm terminal pitch employment is equal to I.C.'s terminal pitch.
4. Employment of suitable plastic materials is to be applied to high temperature condition and various chemical solutions.
5. Complete protective construction is designed from dust and soldering flux. If required, the plastic sealed type is available for washing procedure.

Contact Rating

Load Type	UDH (DM/DB)	UDH (D)
Rated Load (Resistive)	12A 120 VAC	12A 120 VAC
	10A 250 VAC	10A 250 VAC
	12A 24 VDC	12A 24 VDC
Rated Carrying Current	12A	12A
Max. Allowable Voltage	AC 240V,	AC 240V
	DC 110V	DC 110V
Max. Allowable Current	12A	12A
Max. Allowable Power Force	2,500VA	2,500VA
	280W	280W
Contact Material	Ag Alloy	Ag Alloy
Contact Form	SPST	SPDT

Application

Cooking Appliances, Air Conditioners, Audio Equipment, Domestic Appliances, Car Control Units, etc.

Performance (at Initial Value)

- Contact Resistance 100mΩMax. @1A,6VDC
- Operate Time..... 7 mSec. Max.
- Release Time 4 mSec. Max.
- Dielectric Strength:
 - Between Coil & Contact 2,000VAC at 50/60 Hz for one minute.
 - Between Contacts 750VAC at 50/60 Hz for one minute.
- Surge Strength 5,000V (between Coil. & Contact 1.2x50μSec.)
- Insulation Resistance 100 MegaΩ Min. at 500VDC.
- Max. On/Off Switching :
 - Electrical..... 6 Cycles per Minute.
 - Mechanical 300 Cycles per Minute.

- Temperature Range-30~65°C
- Humidity Range45~85% RH.
- Coil Temperature Rise40°C Max. (3~24V)
50°C Max. (48V)
- Vibration:
 - Endurance.....10 to 55 Hz dual amplitude width 1.5mm.
 - Error Operation10 to 55 Hz dual amplitude width 1.5mm.
- Shock :
 - Endurance1,000 m/S².
 - Error Operation100 m/S².
- Life Expectancy :
 - Mechanical10⁷ Operations at No Load condition.
 - Electrical10⁵ Operations at Rated Resistive Load.
- Weight.....About 9.5 g.

Safety Standard & Its File Number

- UL & C-UL.....E141060

Coil Specification (at 20°C)

Coil Sensitivity	Nominal Voltage (VDC)	Nominal Current (mA)	Coil Resistance ($\Omega \pm 10\%$)	Power Consumption (W)	Pull-In Voltage (VDC)	Drop-Out Voltage (VDC)	Maximum Allowable Voltage (VDC)
UDH-D/DM	3	150	20	Abt. 0.45	75% Maximum	5% Minimum	130%
	5	86.2	56				
	6	75	80				
	9	50	180				
	12	37.5	320				
	24	20.9	1,150	Abt. 0.66			
	48	13.7	3,500				

Ordering Information

UDH - SS - 1 12 D M

Contact Form:	Nil: One Form C M: One Form A B: One Form B
Coil Type:	D: Standard DC Coil
Coil Voltage:	03: 3V, 05: 5V, 06: 6V, 09: 9V, 12: 12V, 24: 24V, 48: 48V
Number of Pole:	1: One Pole
Type of Sealing:	SS: RT II Flux Proofed Relays SH: RT III Wash Tight Relays
Type:	UDH

Classification

Model	UDH		
Contact Form	1C	1A	1B
Flux Proofed Relay	UDH-SS-1□□D	UDH-SS-1□□DM	UDH-SS-1□□DB
Wash Tight Relay	UDH-SH-1□□D	UDH-SH-1□□DM	UDH-SH-1□□DB

Dimension ($\leq 5\text{mm} \pm 0.2\text{mm}$, $> 5\text{mm} \pm 0.3\text{mm}$, the tolerance of PCB thru hole: $+0.1\text{mm}$)
UDH-SS/SH

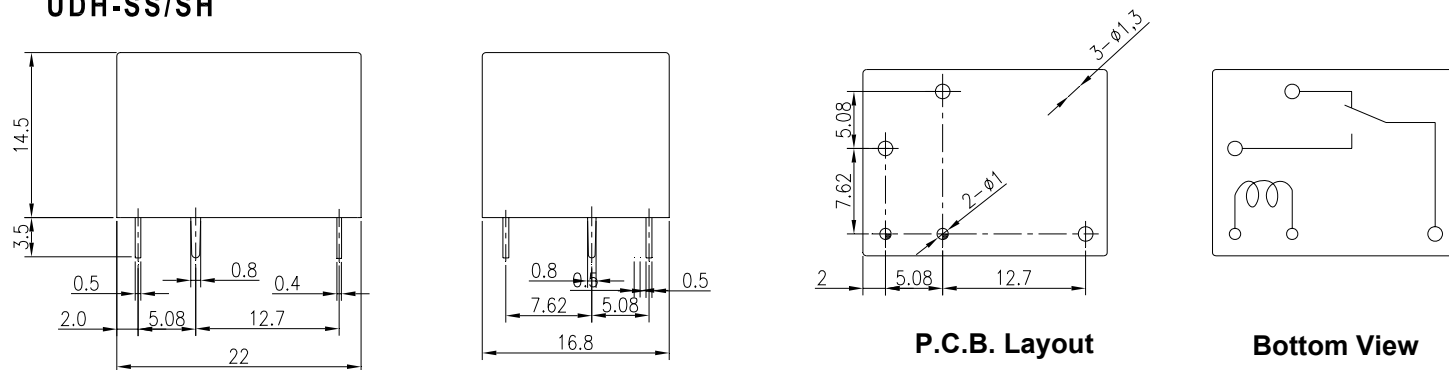

Reference Data

